

## 2. Technical drawings

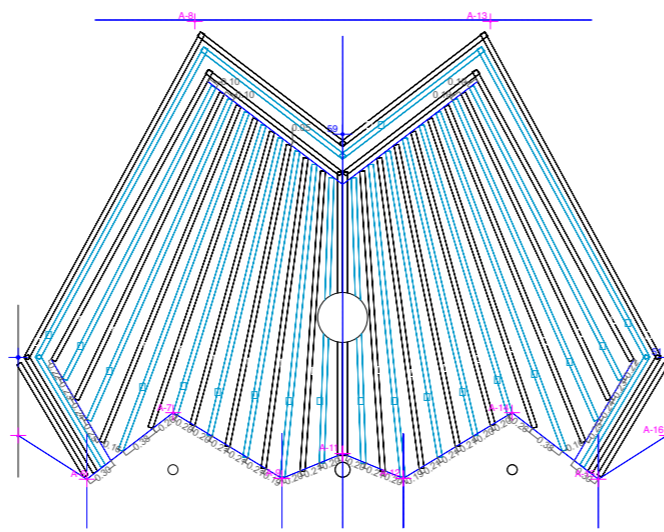

Kite. Construction process.

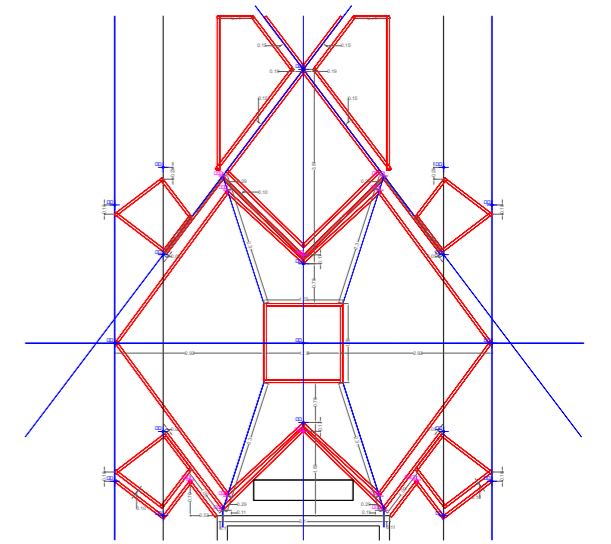
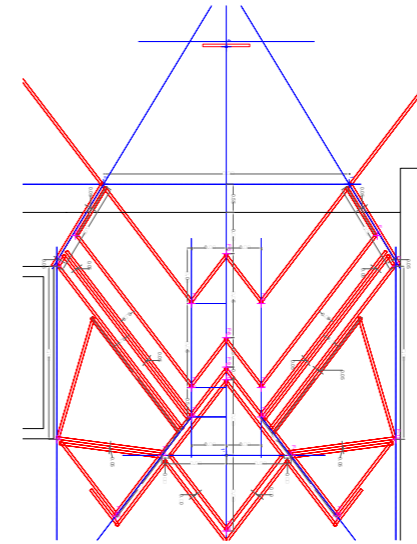
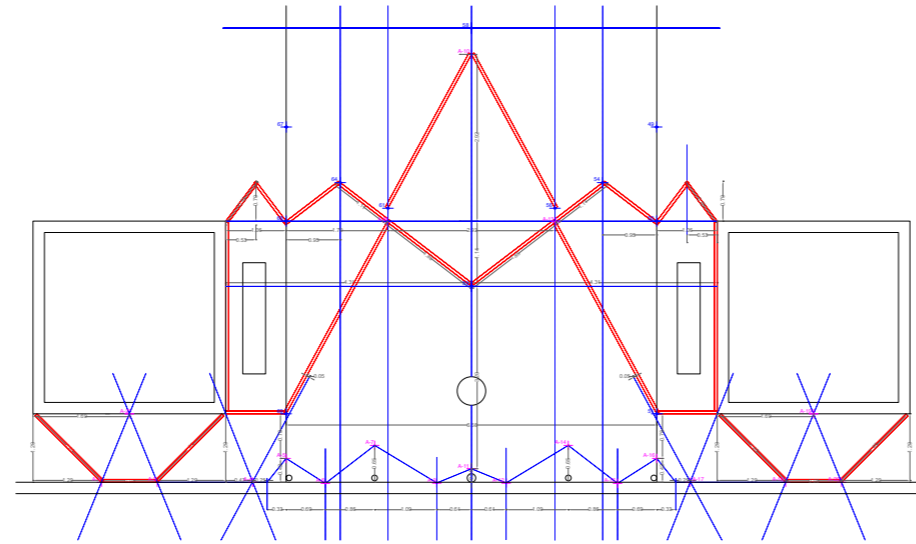
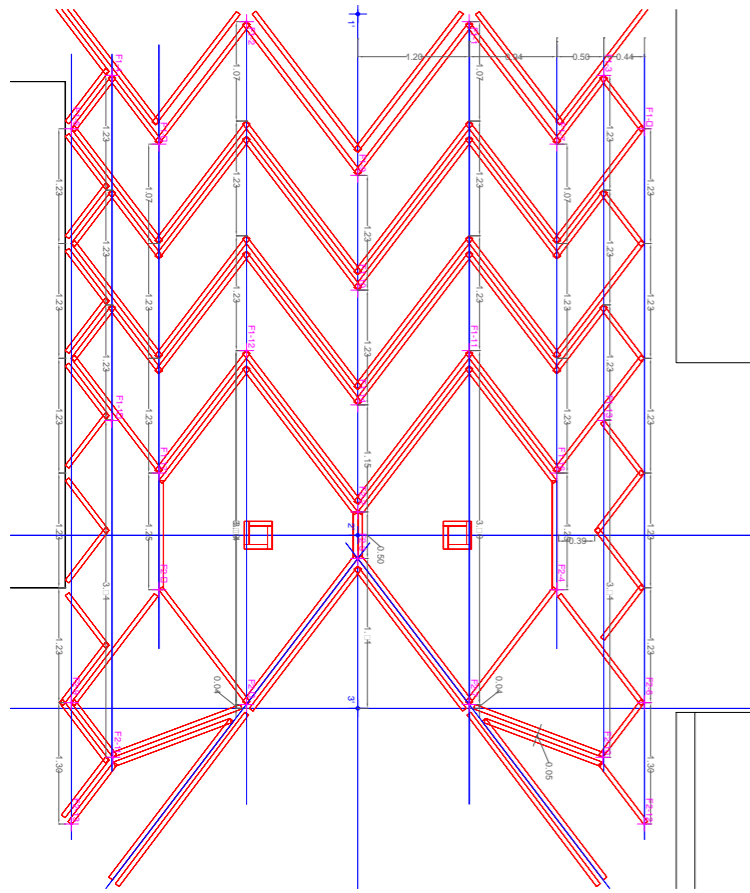
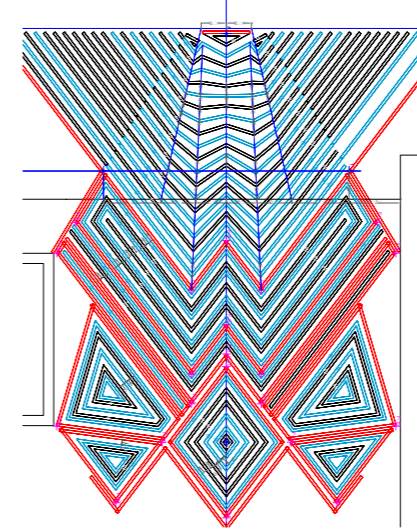

Fish. Construction process.

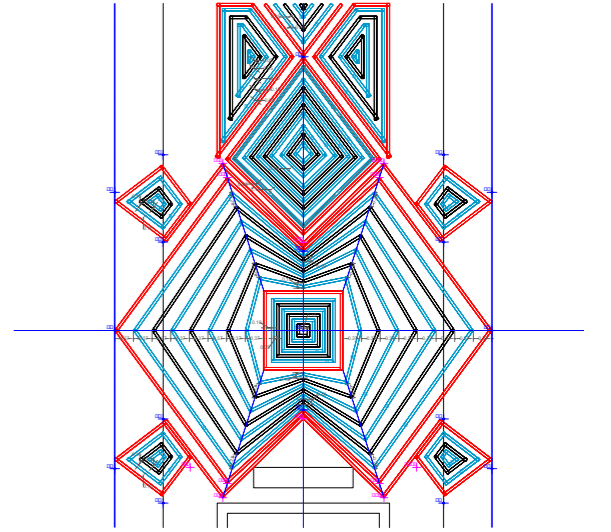

Turtle. Construction process.

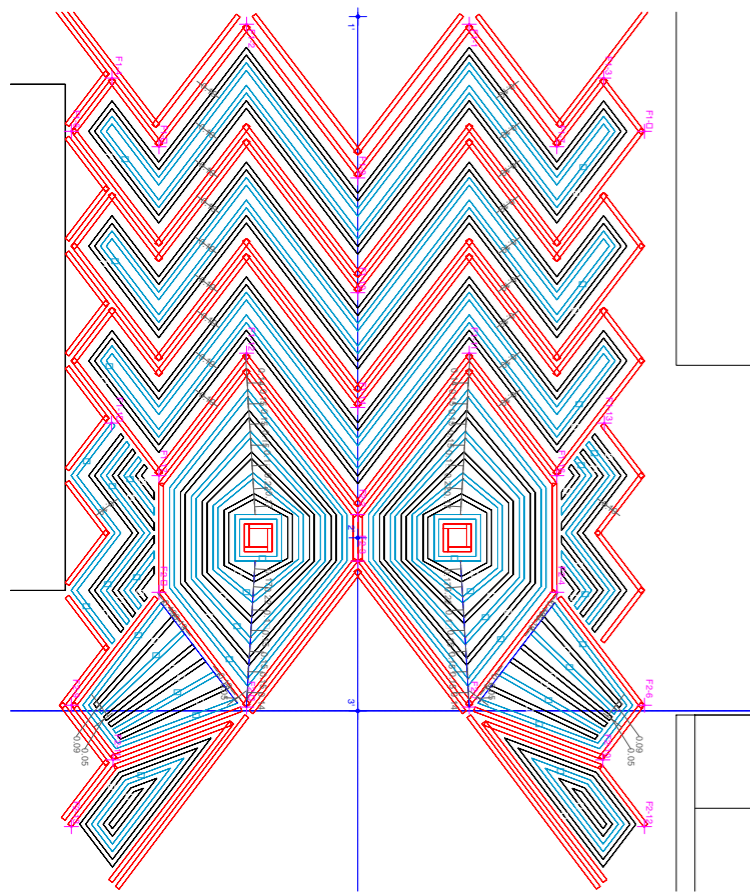

Fish. Detail of the technical drawing.



The carefully planned aspect of the design helped people feel less intimidated by the demand of creativity and more willing to take part within a process of shared responsibilities, where an extravagant drawing met a series of organised and driven hierarchies. Daily, all technical drawings were hanged on the walls for participants to follow the construction process as well as for passers-by to stop and gain a more clear understanding of the project. During this phase, school classes joined the workshop during their art classes, enhancing the sense of horizontal public involvement that the project aimed to instill within the whole neighborhood.