

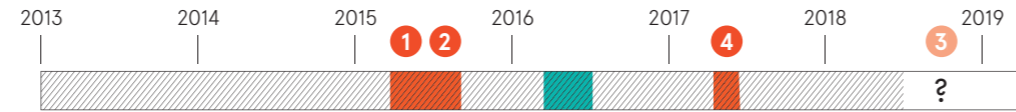

A LONG AND COLLECTIVE PROCESS

Urban acupuncture



2013
Cabanon Vertical started to get involved in Bellevue, the social housing part of Saint-Mauront district.

2015
After 2 years of research, the first 2 Geckos are built at a 3-month interval as « urban-transitory form »

2017
4 years later, Gecko #4 is designed as a sustainable form, as the outcome from a long and collective process

2018 ?
Gecko #3 was supposed to be built in 2016. The project, already co-designed, is on hold due to an institutional impasse



Spring 2016 - In situ, a « street-office » to present the first sketches to the inhabitants



April 2017 - Three young inhabitants involved in the building process (social reinsertion)



May 2017 - Planting session with children of the primary School Bellevue

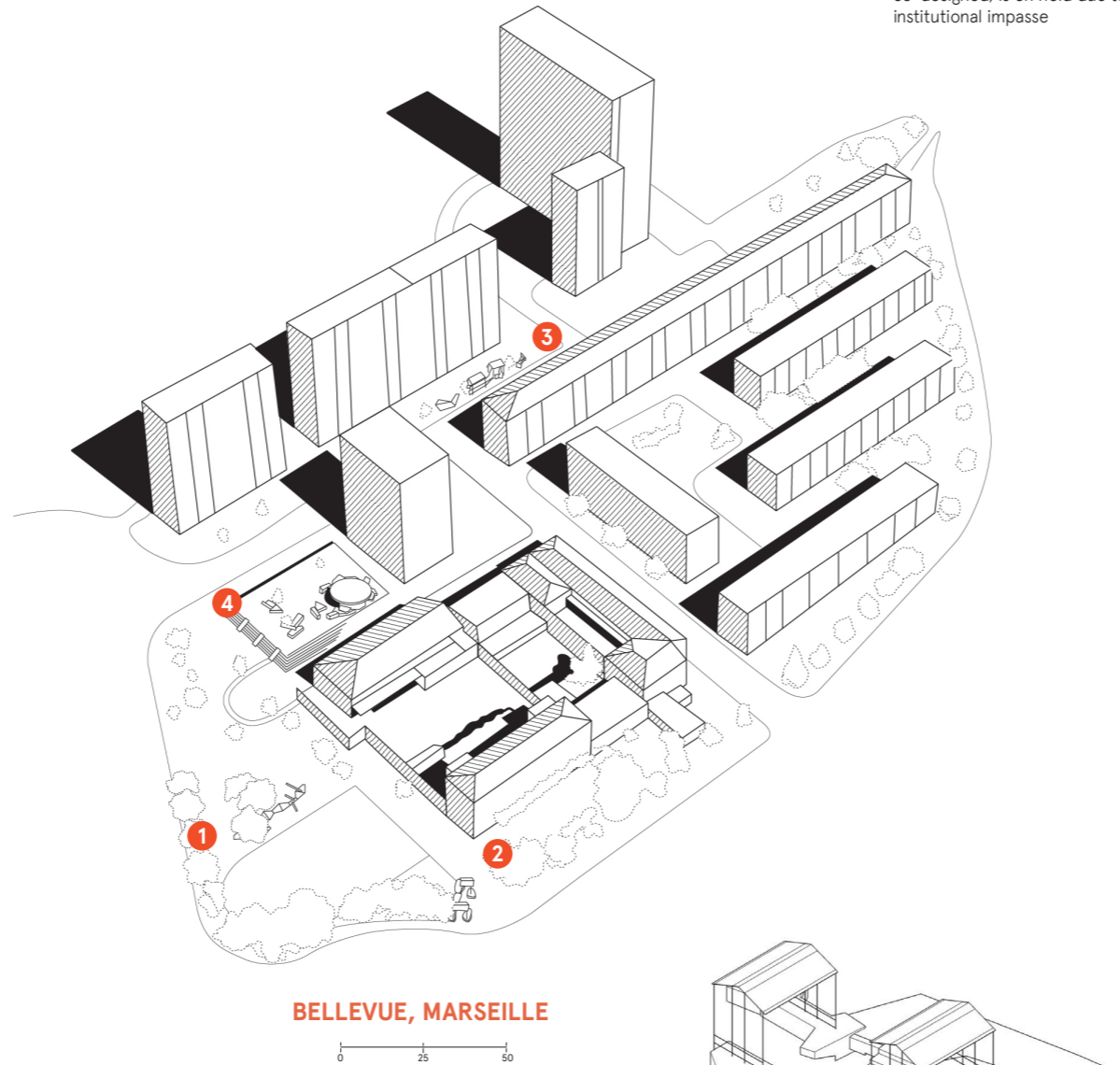

BELLEVUE, MARSEILLE

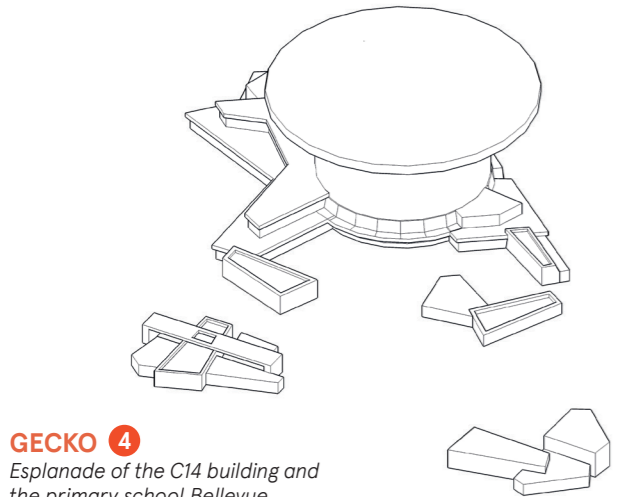

GECKO 4

Esplanade of the C14 building and the primary school Bellevue

Meeting space for family, children and even young girls.

Co-design 2016
Co-construction 2017
Area 460 m²
Cost 195 000 € (including concertation)
Developpers Landlord Marseille Habitat, Fondation de France, City of Marseille, Département des Bouches-du-Rhône, Aix Marseille Provence Métropole

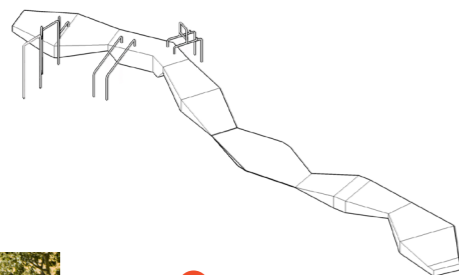

GECKO 1

A street workout place (outdoor bodybuilding equipment) next the stadium

Meeting and playing place for children, teenagers and sportsmen.

Co-design 2014
Co-construction 2015
Cost 40 000 €
Developpers Fondation de France, City of Marseille, Région PACA



GECKO 2

The so-called « Gamazé Place »

Sud entrance in the social housing area Bellevue. Meeting place for the Comorians men in all Marseille.

Co-design 2014
Co-construction 2015
Cost 40 000 €
Developpers City of Marseille, Région PACA, Fondation de France